

**CD15.5F**

**FLAMESHIELD FS120 JM TUBE MOTOR FIRE SHUTTER HEADBOX CONFIGURATION - SECTIONS**

FLAMESHIELD FS120 JM  
HEAD BOX SIZE A: 350 x 350mm  
MOTOR ENDPLATE A: 550 x 350mm

OVERALL WIDTH (D)	OVERALL HEIGHT (E)
8000	3375

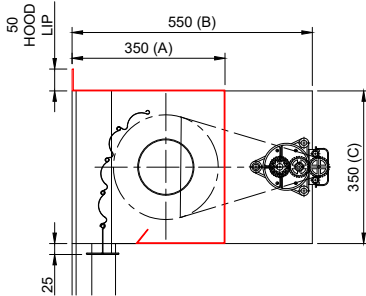

FLAMESHIELD FS120 JM  
HEAD BOX SIZE B: 400 x 400mm  
MOTOR ENDPLATE B: 600 x 400mm

OVERALL WIDTH (D)	OVERALL HEIGHT (E)
8000	2425

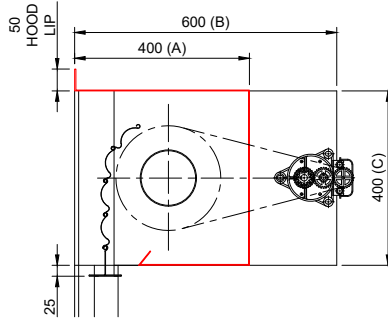

FLAMESHIELD FS120 JM  
HEAD BOX SIZE B: 450 x 450mm  
MOTOR ENDPLATE B: 650 x 450mm

OVERALL WIDTH (D)	OVERALL HEIGHT (E)
8000	6900

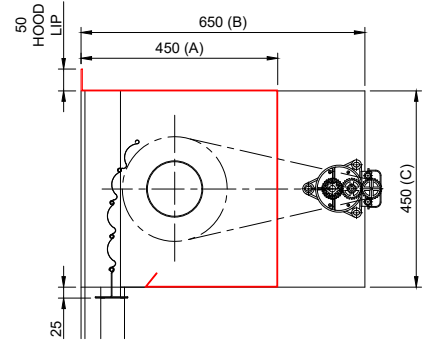

- A x C = NON-MOTOR END PLATE
- B x C = MOTOR END PLATE

- \* FIRE SHUTTER SIZES ARE GOVERNED BY THE STRUCTURE AND FIRE RATING REQUIRED
- \* RED SECTION DENOTES FULL WIDTH HOOD - MUST BE ACCESSIBLE FOR REPAIR AND MAINTENANCE PURPOSES
- \* ADDITIONAL SIZES AVAILABLE ON REQUEST - SUBJECT TO CERTIFICATION

Drawing Title: FLAMESHIELD FS120 JM FIRE SHUTTER	Drawn By: DD
	Date: 05-12-2023
	Checked By: CE
	Date: 05-12-2023
All dimensions in millimetres - DO NOT SCALE	Drawing No: CD15.5F_01



A1 Shutters Limited  
Jackson Works  
Raikes Lane Industrial Estate  
Bolton BL3 2NH  
Telephone 01204 383839

**FLAMESHIELD FS120 JM FIRE SHUTTER GENERAL ARRANGEMENT DRAWING: FACE FIT**

**CD15.5F**

**Key:**  
— Components supplied by A1S Group  
— Structure already in situ

All openings must be capable of carrying the weight of the fire shutter and be equal or greater than the fire resistance of the fire shutter assembly.

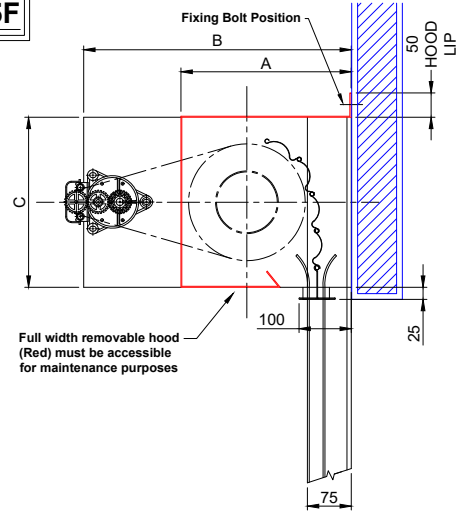
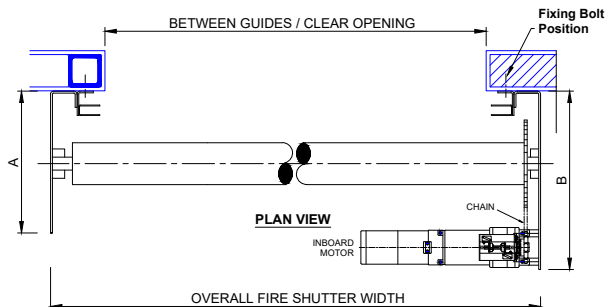
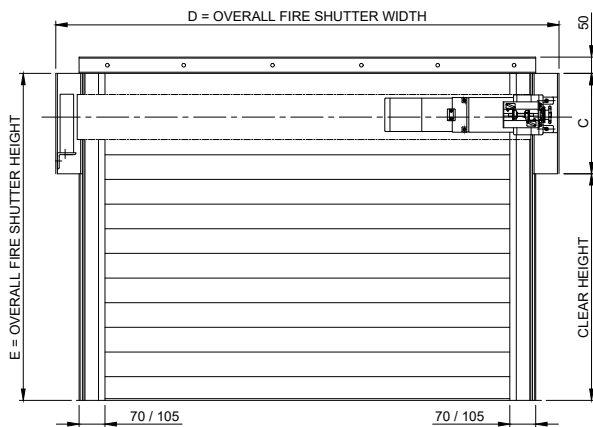

GUIDES CHANGE FROM STANDARD TO OVERSIZED AT 7000mm+ OVERALL WIDTH

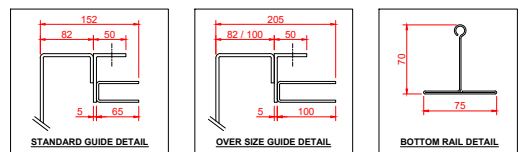

FIRE RATING	120 MINS
FIRE RATED STRUCTURE	STEEL / MASONRY

Description: FLAMESHIELD FS60JM FIRE SHUTTER	Drawn By: DD
	Date: 05-12-2023
	Checked By: CE
	Date: 05-12-2023
All dimensions in millimetres - DO NOT SCALE	Drawing: CD15.5F-02



A1 Shutters Limited  
Jackson Works  
Raikes Lane Industrial Estate  
Bolton BL3 2NH  
Telephone 01204 383839